

NOTES:

(NI) 1. FIT / FORM / FUNCTION SHALL FOLLOW PS-E.008.

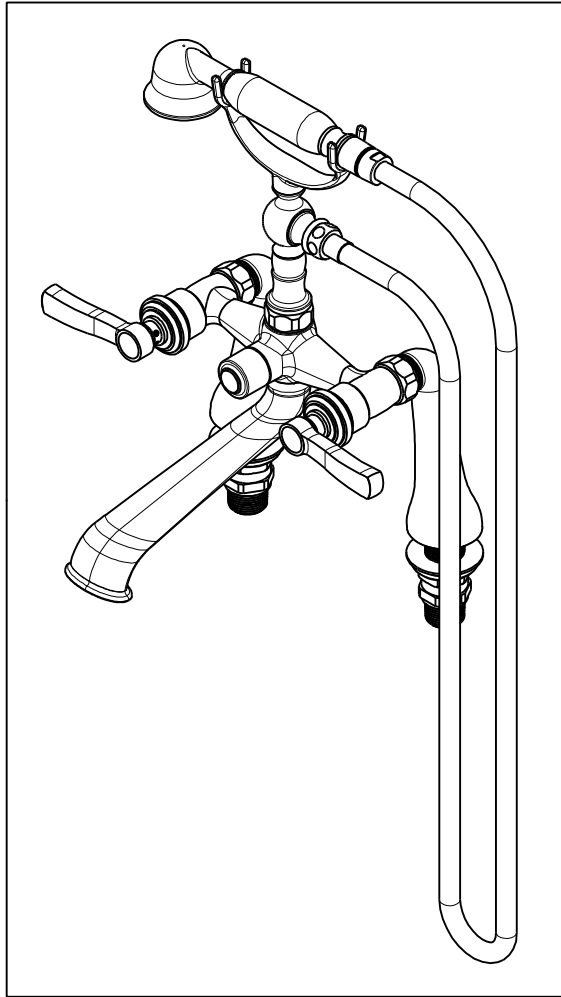

BILL OF MATERIAL (CURRENT LEVEL)

ITEM	PT/ASSY	DESCRIPTION	TYPE	QTY.
1	12894	BODY - FOR 933,934	PART	1
2	2-220	RISER ASM	ASSEMBLY	1
3	284_	59 IN. SPIRAL SHOWER HOSE	ASSEMBLY	1
4	281	HANDSHOWER ASM	ASSEMBLY	1
5	12585	SPOUT	PART	1
6	91028	O-RING, #2- 018, EPDM, 65-75 DURO, NSF 61	PART	1
7	1-325	W/S CARTRIDGE FRICTION - COLD	PART	1
8	1-326	W/S CARTRIDGE FRICTION - HOT	PART	1
9	12062	ADAPTER - 20-T X 16-T	PART	2
10	10442	SEAT FOR CARTRIDGE	PART	2
11	91020	O-RING, #2-016, EPDM, 65-75 DURO, NSF 61	PART	2
12	10332	HEX NUT	PART	2
13	91039	WSHR, .625 ID X 1.00 OD X .125 THK, RUBBER	PART	2
14	10336	LEG - LEFT	PART	1
15	10335	LEG - RIGHT	PART	1
16	1-049	MOUNTING HARDWARE	ASSEMBLY	1
17	92539	SCRW, M4X22 FLAT HD SOCKET HD CAP	PART	2
18	12520	BONNET	PART	2
19	2-362	HANDLE ASSEMBLY	ASSEMBLY	2
20	20-260	DIVERTER ASM	ASSEMBLY	1
21	20-259	DIVERTER ASM	ASSEMBLY	1
22	13313	DIVERTER BUTTON	PART	1

EN-4123  
C.GAYOSSO 03/04/2020

ZONE	REV	DESCRIPTION	DATE	APPROVED
-	C	EN-3565A	01/30/20	C.G.
-	B	EN-3447	10/27/17	V.V.
-	A	EN-3150a	05/18/17	J.M.
-	-	EN-3058b	09/13/16	AN

COPYRIGHT 2005 BRASSTECH, INC. THESE DRAWINGS AND THE DESIGNS DEPICTED HEREIN ARE THE PROPRIETARY PROPERTY OF BRASSTECH. ANY USE OR REPRODUCTION IS SUBJECT TO THE EXPRESS APPROVAL OF BRASSTECH. UNAUTHORIZED USE IS STRICTLY PROHIBITED. ALL RIGHTS RESERVED.

TESTING	-	-	-
ASSEMBLY	-	-	-
PLATING	-	-	-
POLISHING	-	NEXT ASSY	USED ON
MACHINING	-	APPLICATION	
TOOLING FIXTURE #	REMOVE ALL BURRS AND SHARP EDGES		

UNITS ARE: INCHES [MM]	
TOLERANCES ARE:	
FRACTIONS DECIMALS	ANGLES
±1/16"	±°
.X ±.1 [2,5]	
.XX ±.06 [1,5]	
(X.XXX) DENOTES CRITICAL DIMS.	
ALL THREADS ARE CRITICAL	
DRAWN	JINSON 01/30/20
CHECKED	C.G. 01/30/20
APPROVED	C.G. 01/30/20

**BRASSTECH** 2001 CARNEGIE AVE.  
INCORPORATED SANTA ANA, CA 92705  
(949) 417-5207

**EXPOSED TUB FILLER, DECK MOUNT**

DWG NO. **2590-4273** REV **D**

SCALE .200 REF. - SHEET 1 OF 3

- 2. APPLY ADHESIVE LOCTITE 680.
- 3. TORQUE TO 15-20 FT-LB.
- 4. APPLY LOCTITE 242 IF SCREW DOES NOT HAVE NYLON PATCH.
- 5. TORQUE TO 11-14 FT-LB.

6. VISIBLE GAP BETWEEN THE SPOUT AND BODY IS ACCEPTABLE UP TO .070".

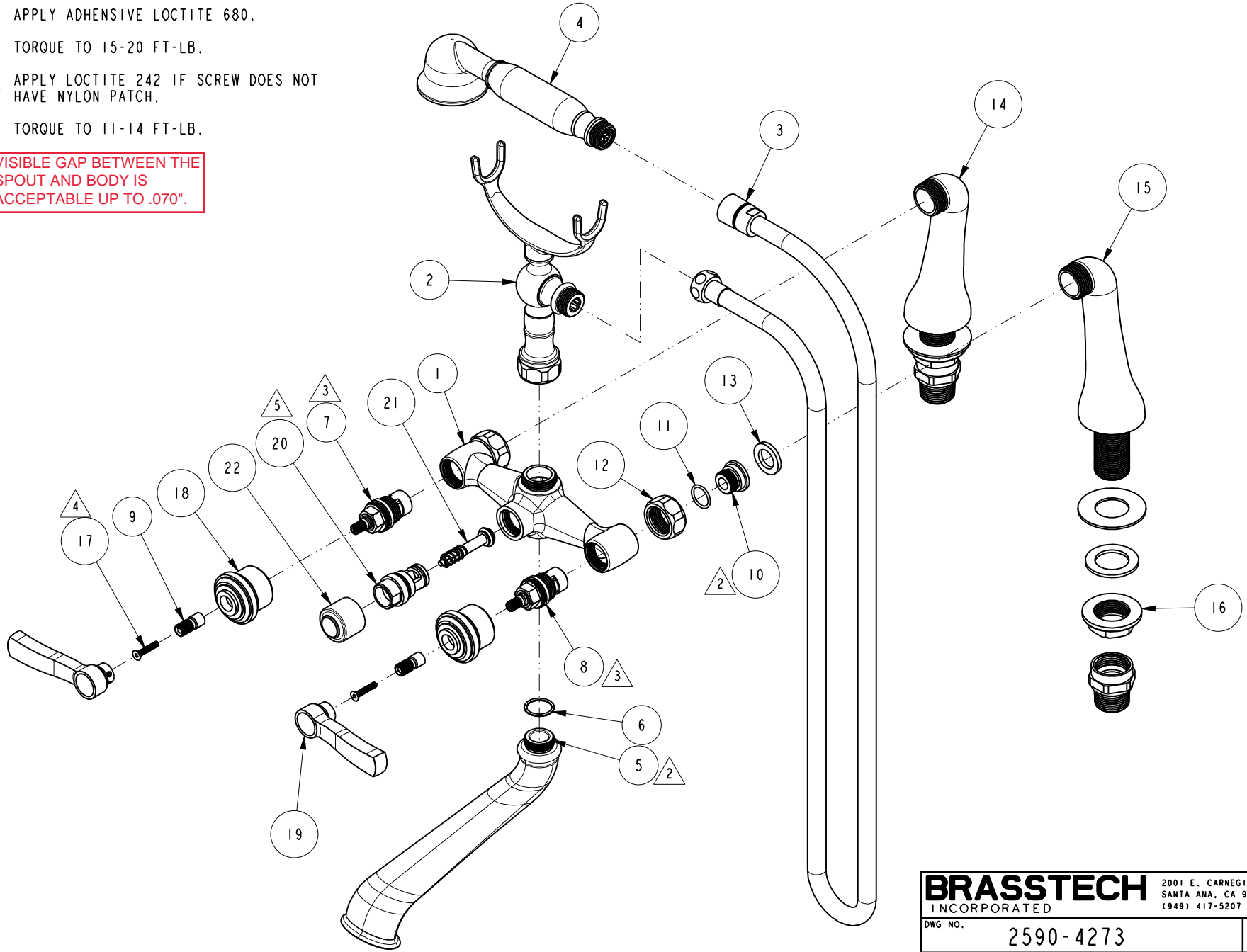

<b>BRASSTECH</b>		2001 E. CARNEGIE AVE. SANTA ANA, CA 92705 (949) 417-5207	
DWG NO.	2590-4273	REV	<b>D</b>
SCALE .250	REF. -	SHEET 2	OF 3

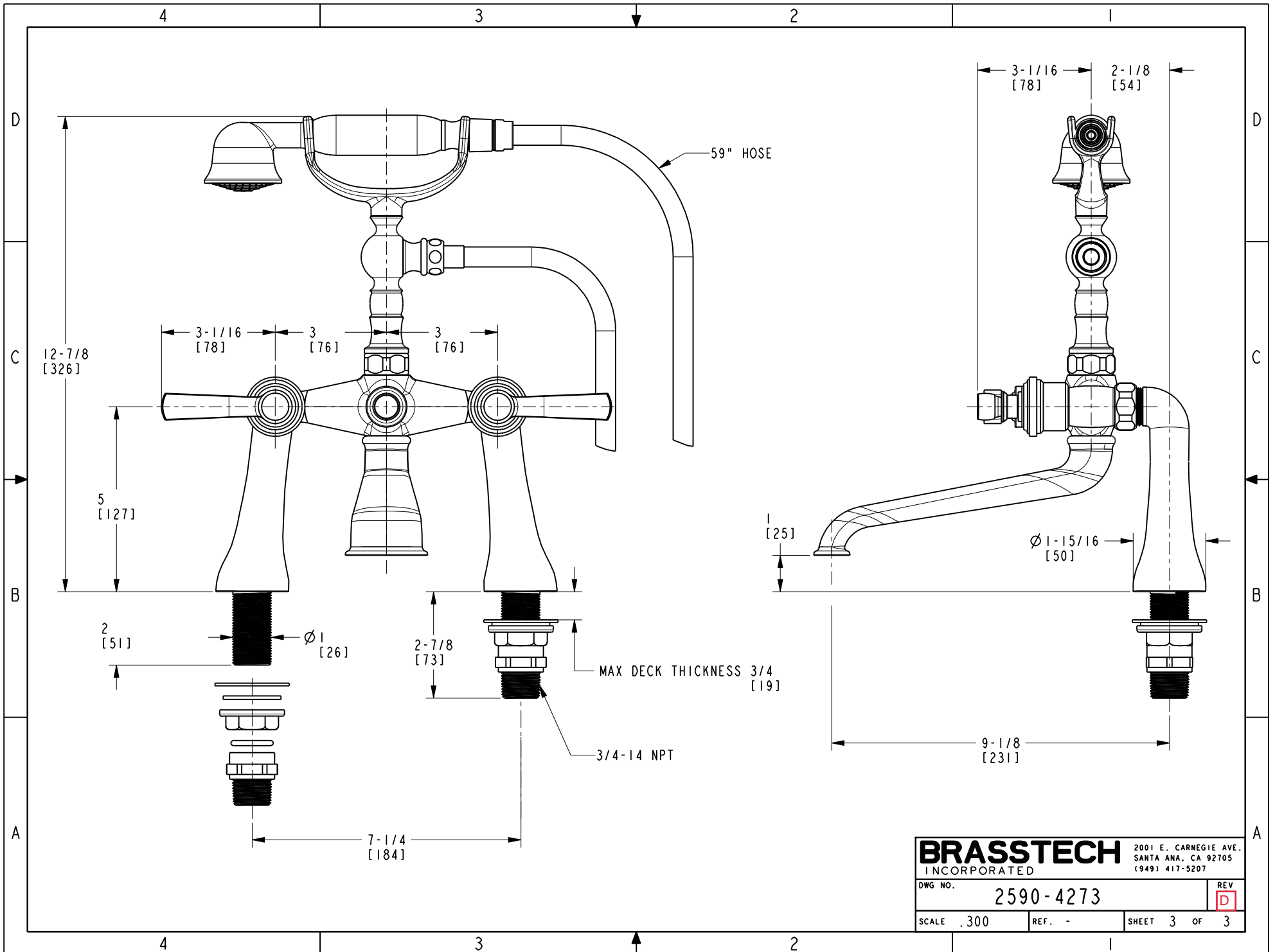

<b>BRASSTECH</b>		2001 E. CARNEGIE AVE. SANTA ANA, CA 92705 (949) 417-5207	
DWG NO.	2590-4273	REV	<b>D</b>
SCALE .300	REF. -	SHEET 3	OF 3