

4

3

2

1

D

D

C

C

B

B

A

A

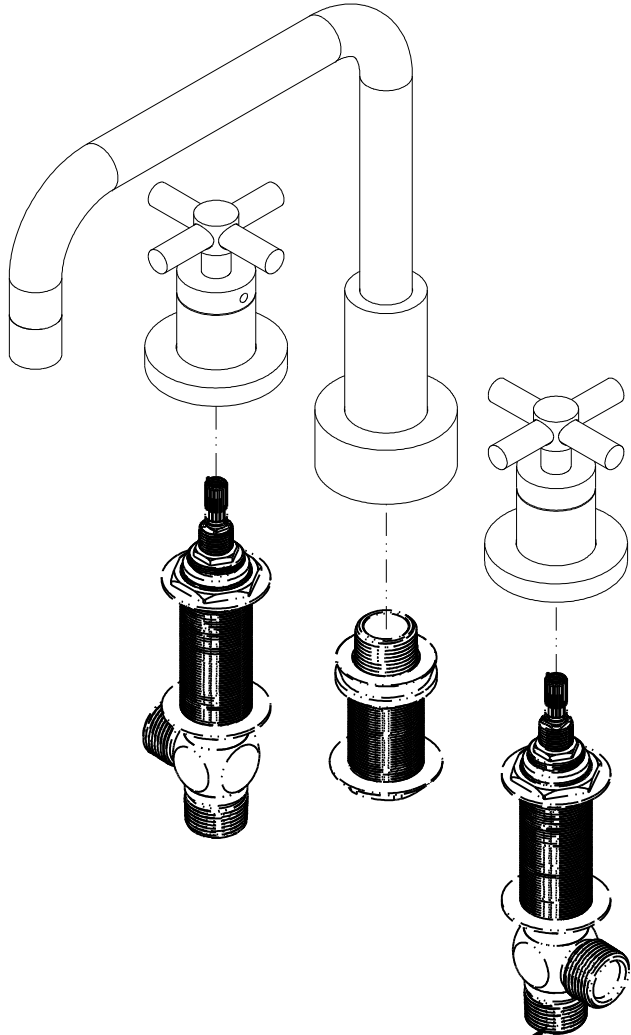

PN # : 1-502 SOLD SEPARATELY

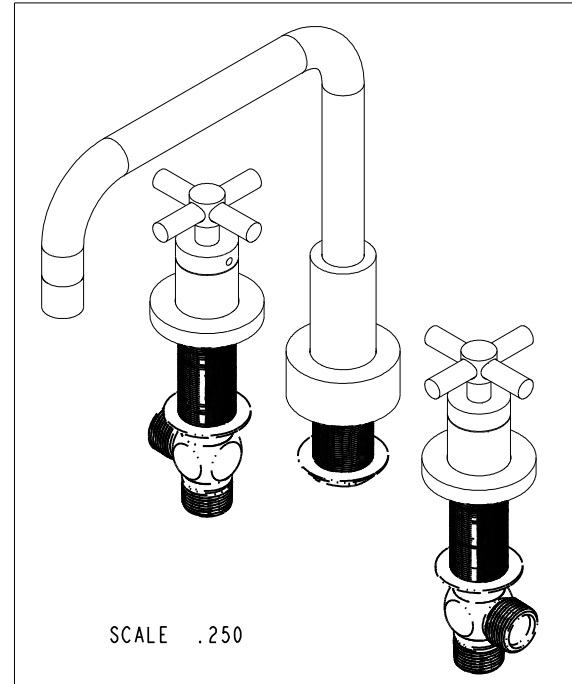

SCALE .250

BRASSTECH		2001 E. CARNEGIE AVE. SANTA ANA, CA 92705 (949) 417-5207	
DWG NO.	3-1406	REV	C
SCALE	.313	REF.	-
		SHEET	2 OF 3

4

3

2

1

