

NOTES:

1. TO INSPECT ASSEMBLY, FOLLOW FIRST ARTICLE AND IN PROCESS INSPECTION SHEET.

BILL OF MATERIAL (CURRENT LEVEL)

ITEM	PT/ASSY	DESCRIPTION	TYPE	QTY.
1	5083SO	24" GRAB BAR BRAZE ASM	ASSEMBLY	1
2	1995	MOUNTING FLANGE	PART	2
3	199X	GRAB BAR MOUNTING HARDWARE PACK	ASSEMBLY	2
4	40679	DECORATIVE RING	PART	2

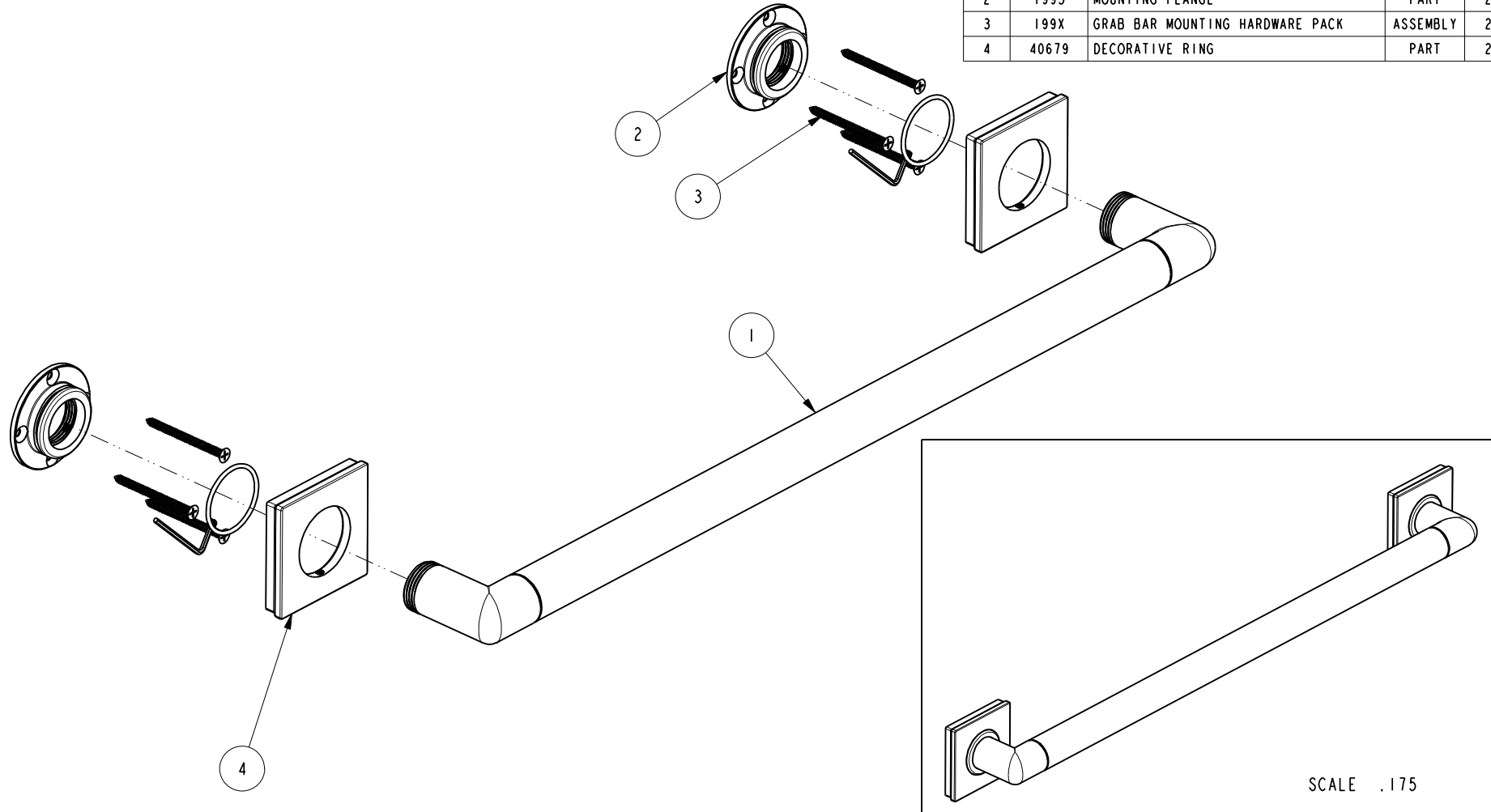

SCALE .175

UNITS ARE: INCHES [MM]

TOLERANCES ARE:

FRACTIONS DECIMALS ANGLES
 $\pm 1/16"$.X $\pm .1$ [2,5] $\pm 1^\circ$
 .XX $\pm .06$ [1,5]

(X.XXX) DENOTES CRITICAL DIMS.
 ALL THREADS ARE CRITICAL

DRAWN JINSON 06/22/21
 CHECKED R.S. 06/22/21
 APPROVED R.S. 06/22/21

BRASSTECH
 INCORPORATED

2001 CARNEGIE AVE.
 SANTA ANA, CA 92705
 (949) 417-5207

GRAB BAR 24"

DWG NO. 3140-3924

REV B

SCALE .275

REF. -

SHEET 1 OF 2

ZONE	REV	DESCRIPTION	DATE	APPROVED
-	B	EN-4300i	06/22/21	R.S.
-	A	EN-4143	03/20/20	J.M.
-	-	EN-3279b	04/17/17	J.M.

COPYRIGHT 2005 BRASSTECH, INC.
 THESE DRAWINGS AND THE DESIGNS
 DEPICTED HEREIN ARE THE PROPRIETARY
 PROPERTY OF BRASSTECH. ANY USE
 OR REPRODUCTION IS SUBJECT TO
 THE EXPRESS APPROVAL OF BRASSTECH.
 UNAUTHORIZED USE IS STRICTLY
 PROHIBITED. ALL RIGHTS RESERVED.

TESTING	ASSEMBLY	PLATING	POLISHING	MACHINING	TOOLING FIXTURE #	APPLICATION
-	-	-	-	-	-	-
-	-	-	-	-	-	-
-	-	-	NEXT ASSY	USED ON	-	-
-	-	-	-	-	-	-
-	-	-	-	-	-	REMOVE ALL BURRS AND SHARP EDGES

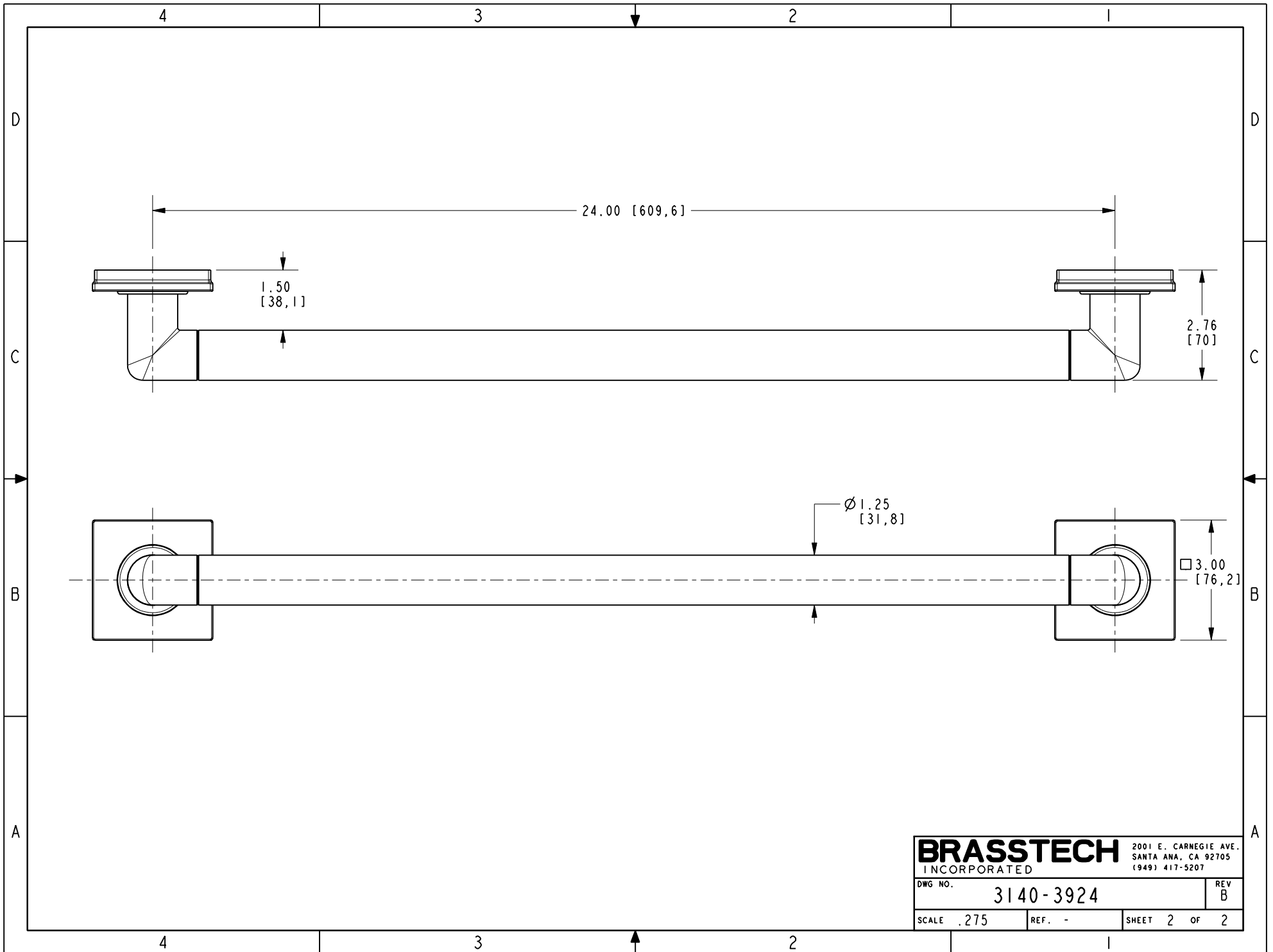

BRASSTECH		2001 E. CARNEGIE AVE.
INCORPORATED		SANTA ANA, CA 92705
		(949) 417-5207
DWG NO.	3140-3924	REV B
SCALE .275	REF. -	SHEET 2 OF 2